

\$511,000

Lot 10 The Link, Rolleston



For Sale

House and Land Package

Dwelling Size	Section Size				
157m ²	471m ²	4	1	2	2

This home features four bedrooms, master with walk-in robe and ensuite, open plan kitchen living and dining, family bathroom and internal access double garaging. Well appointed for the sun on an easy care landscaped section, offering quality fixtures and fittings throughout and finished to a high standard this design is sure to impress.

Just twenty minutes from Christchurch, Rolleston has so much to offer. You are spoilt for choice within New Zealand's fastest growing area. Offering retailers, eateries, parks and reserves along with a newly established primary school and Rolleston college in close proximity. Only for a short drive to central Rolleston with a shopping complex to cater all requirements.

Lot 10 The Link, Rolleston

Inclusions:

Quality cladding selections

1.98m internal door height

Bosch appliances

Norman Ellison carpets

Window coverings

Metal pressed tile roof

Windsor door hardware

Italian tapware

8.0kw heatpump

After care service

2.42m ceiling height

Designer kitchen

LED light fittings

Fully landscaped

10 year Master Build guarantee

Floor Plan:

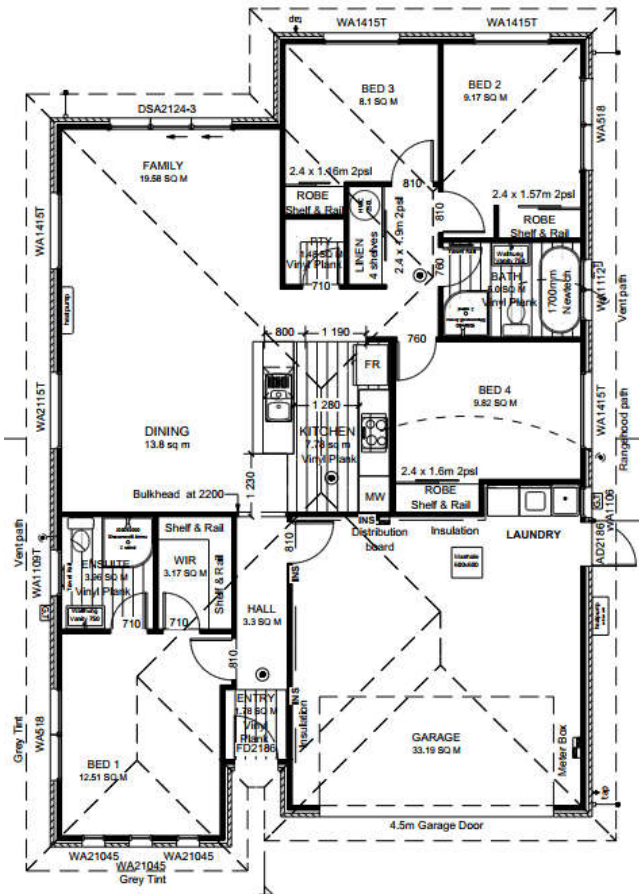

Location:

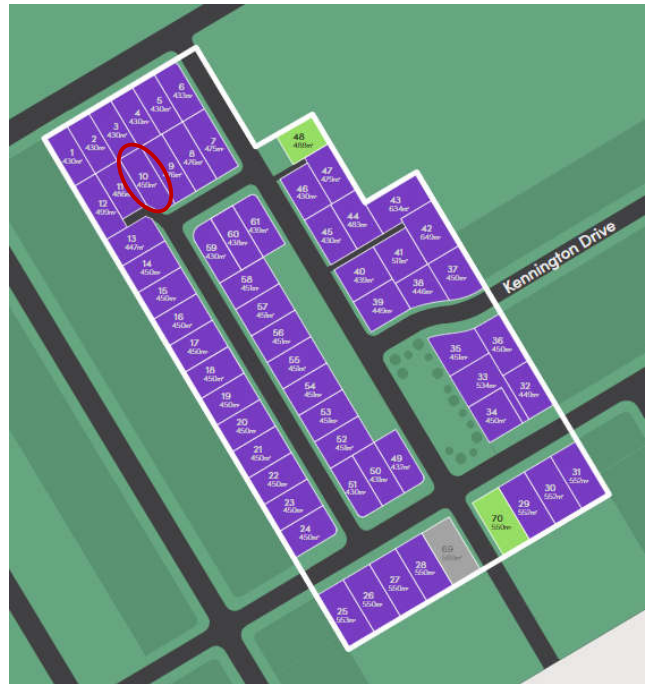

Disclaimer: This material is for the use of illustrative and guidance purposes. All efforts have been made by Stonewood Homes Christchurch to ensure the information correctly illustrates the dwelling however Stonewood Homes accept no responsibility for any variances which may become apparent once the build commences.

Specification

Lot 10 The Link, Rolleston

GENERAL

Guarantee:	10 year Master Build guarantee
Warranty:	365 day warranty period
Insurance:	Builders risk insurance

STRUCTURE

Foundation/floor slab:	TC1 Ribraft
Framing:	2.42m NZS 3602:2003 with building wrap – 90mm kiln dried pine
Trusses:	Kiln dried pine
Cladding (main):	Brick – Midland Brick 70 series – Modus series

ROOFING

Roof:	25° Gerard metal pressed tile
Downpipes:	Colorsteel rectangular 75x55mm
Fascia and gutter:	Dimond metal fascia and quad gutter

WINDOWS AND DOORS

Entry door:	APL 860mm Latitude with urbo lever
Windows:	Vantage aluminium joinery with urbo hardware
Garage door:	Coloursteel flat panel woodgrain 4.5m
Internal doors:	1980mm Everest (vertical V groove polycore)
Wardrobe doors:	MDF flush panel sliders
Window coverings:	Roller blinds excluding garage and bathrooms

INTERIOR LINING

Insulation:	R2.4 wall batts, R4.0 ceiling batts excluding garage
Plasterboard:	GIB board - 10mm to walls, aqualine to bathrooms and 13mm to ceilings
Gib stopping:	Grade 4 paint finish in accordance with AS/NZ 2311:2009
Gib external corners:	Gib square stop
Painting:	Resene Zylone
Soffit linings:	Hardiflex 4.5mm

INTERIOR JOINERY

Internal door hardware:	Windsor Futura – Apex brushed nickel
Skirting:	60mm bevel
Wardrobe shelving:	MDF shelf and rail
Cupboard shelving:	MDF shelves x4

Specification

Lot 10 The Link, Rolleston

KITCHEN AND LAUNDRY

Kitchen and bench surface:	Kitchen cabinetry and sink with TriStone 12mm on negative detail
Tapware:	Paffoni Blu BLU180 high spout
Oven:	Bosch HBF133BSOA – stainless steel oven
Hob:	Bosch PKE611CA1A – stainless steel cooktop
Dishwasher:	Bosch SMU50E75AU – stainless steel dishwasher
Rangehood:	Bosch DWP96BC50A 600m3 – stainless steel canopy
Laundry tub:	Aquatica Estasi 560x560 LE6200

FLOORING

Carpet:	Norman Ellison
Vinyl planking:	Karndean Knightplank

ELECTRICAL

Plugs / Light Fittings:	As per plan
Heatpump:	Fujitsu 8.0kw ASTG24LFCC

BATHROOMS AND PLUMBING

Vanities:	Raymor Brighton 750mm
Mirrors:	1000 x 750 x 4mm polished edge
Toilets:	Englefield Evora with standard seat
Showers:	Arena curved with moulded wall
Bath:	Newtech Indus back-to-wall freestanding bath
Tapware:	Paffoni Blu BLU071
Shower slides:	Paffoni Brio ZSAL194CR
Towel rails:	Newtech 5 ladder square heated towel rail
Extractors:	Weiss Clearflow FV160
Hot water cylinder:	Rheem 250L
Exterior taps:	2

LANDSCAPING

Driveway and patio:	Exposed aggregate
Vehicle crossing:	Included
Soft landscaping:	Hydroseed and planting to street frontage
Fencing:	1.8m timber paling to rear and side boundaries. 1.8m internal timber fencing to developers requirements including gate.
Letterbox and clothesline:	Urban box on post / Sun King folding frame

Pictorial

Lot 10 The Link, Rolleston

Roof profile



Front door

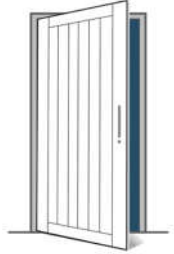

Window hardware

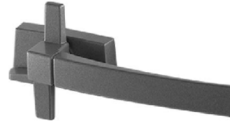

Garage door profile



Internal doors



Internal door hardware



Oven



Ceramic cooktop

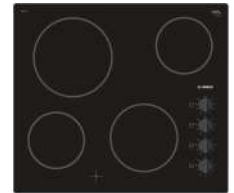

Rangehood



Dishwasher



Laundry tub



Kitchen tapware



Vanity



Showers



Bath



Basin mixers



Shower slides



Shower / bath mixers



Toilet



Towel rail



Colour Scheme

Lot 10 The Link, Rolleston

EXTERIOR

Roof:	Pearl grey
Fascia / Gutter / Downpipes:	Grey friars
Window joinery:	Grey friars
Front door:	Grey friars
Front door frame:	Grey friars
Garage door:	Grey friars
Garage door frame:	Grey friars
Soffits:	Resene half black white
Exterior cladding (main):	Ceniza with natural mortar

INTERIOR

Ceilings:	Resene half black white
Walls:	Resene black white
Interior doors:	Resene black white
Skirting:	Resene black white
Carpet:	Dalton - Woodland
Vinyl plank:	Pale limed oak
Kitchen cabinetry:	Melteca - Snow drift
Kitchen benchtop:	TriStone 12mm – Pure white on black pearl negative detail
Tiles (kitchen splashback):	White tile (100x300mm) with mid-night grout
Aluminium wardrobe surrounds:	White

Exterior:

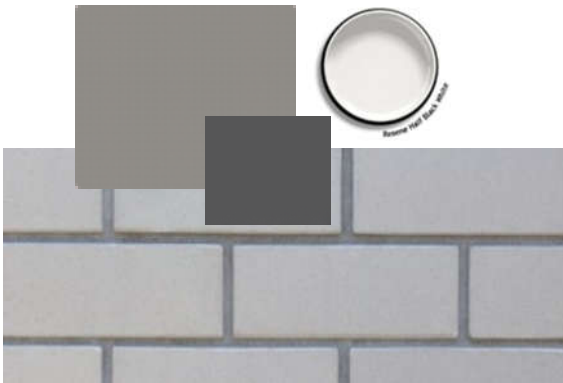

Interior:



Kitchen:

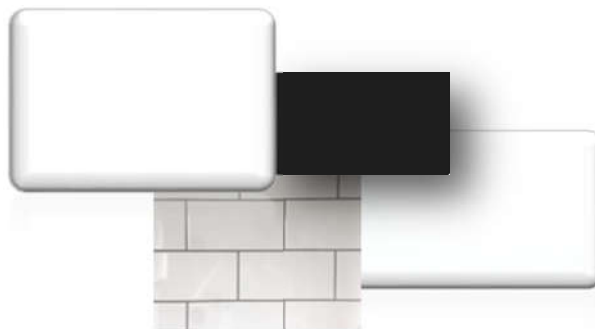

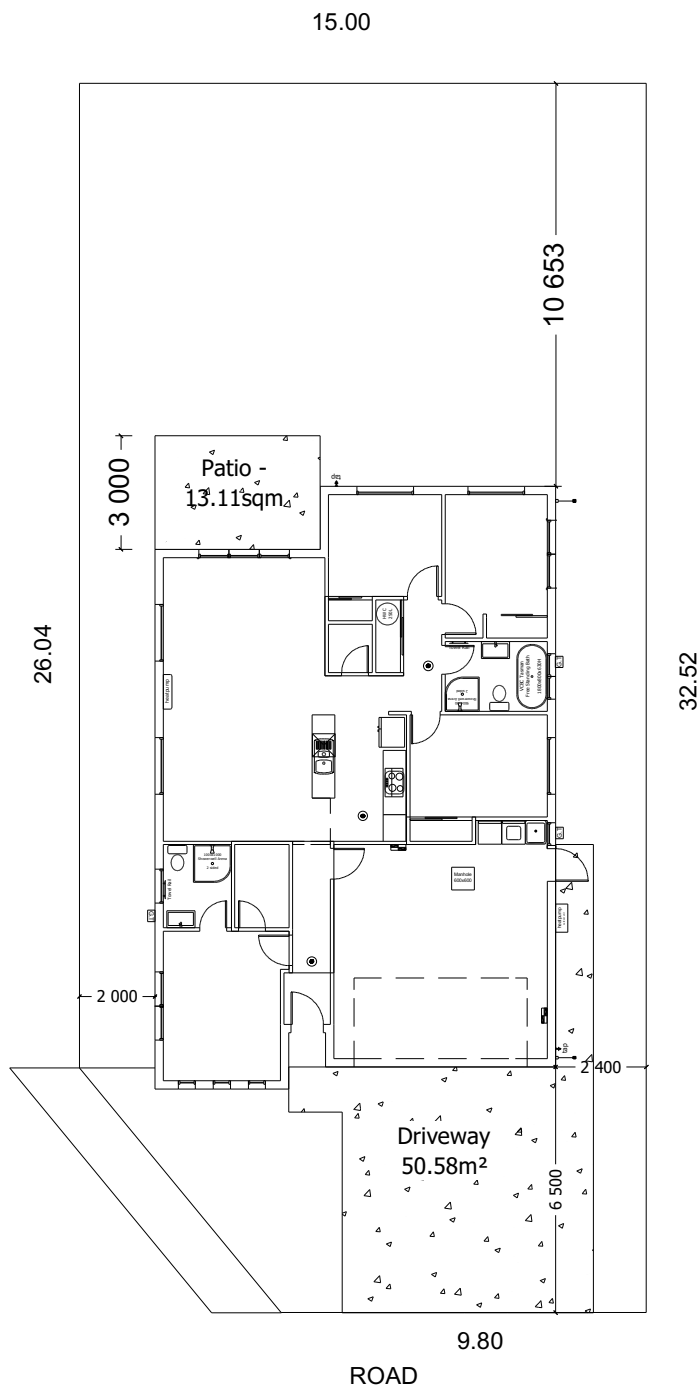
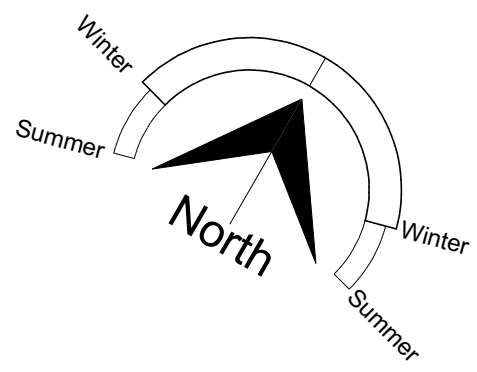

LEGEND	
Sewer Pipe	— developed length: (approx) xxm
S/W Pipe	- - - - developed length: (approx) xxm
Down Pipe	DP
Gully Trap	GT
Terminal Vent	TV

SITE PLAN NOTES

Refer to Drainage Plan for specific drainage information

Refer to sediment control plan in specification and implement where required.

Driveway – By Stonewood Homes as shown OR Driveway and Sump not part of this building consent

Convey surface water from sealed drive areas to an appropriate approved outfall.

Dimensions are shown to cladding face

Resource Consent Issues:
1/ No RC Issues known

SITE INFORMATION	
Zone	xx
Wind	xx
Earthquake	1/2/3/4
Durability	B/C/D
Snow	N x at xxm (up to x kPa)

BUILDING AREA AND SITE COVERAGE	
Net Site Area	=471m ²
Building Area (O/V)	=156.23m ² (Includes covered areas)
Max Site Coverage Allowed	:00%
Actual Site Coverage	=33.16%

EARTHWORKS	
Proposed F.G.L =	xxm
Proposed F.F.L =	xxm
FMA level:	xxm

SITE ASSESSMENT & SOIL REPORT

Site assessment data supplied from:
TBC (registered surveyor)

Phone: TBC
Date completed: xx-xx-xxx
Levels are relative to: TBC

This dwelling has been designed according to the recommendations from:
Soil Report by: xxxxxx
Date: xx-xx-xxxx

STONWOOD HOMES

Stonewood Homes
1B, Level 1, 303 Blenheim Rd
Upper Riccarton, Christchurch 8041,
New Zealand
Phone: +64 3 354 2344
Fax: +64 3 354 2342
Email: info@stonewood.co.nz
Website: www.stonewood.co.nz

Client: Lot 10 The Link, Rolleston
Proposed Dwelling at:
Lot 10 The Link, Rolleston

This plan is developed for the purchaser and is copyright to Stonewood Homes NZ Franchisor Limited.
All dimensions and levels are to be checked and verified on site by contractor prior to commencement of any work

Signed:	Date:		
SITE PLAN			
Drawn By	Checked By	LBP #	
Isha	XXXX XXXXX	XXXXXX	
Standard Plan	Print Date	Sales	Scale at A3
Avon 157 Gable	22/05/2020	SHC	1:200
Job Number	Version	Revision	Sheet
200060	A	2	3
Version:	CONCEPT		OF
			XX



Key To Elevations

WINDOW SCHEDULE	
LABEL	QTY
WA518	2
WA1106	1
WA1112	1
WA1109T	1
WA1415T	4
WA2115T	1
WA21045	3
DSA2124-3	1

DOOR SCHEDULE	
LABEL	QTY
710	3
760	2
810	4
AD2186	1
FD2186	1
2.4 X 1.16M 2PSL	1
2.4 X 1.57M 2PSL	1
2.4 X 1.6M 2PSL	1
2.4 X 1.9M 2PSL	1
4.5M GARAGE DOOR	1

Note:
Grey Tint to Bed 1 windows

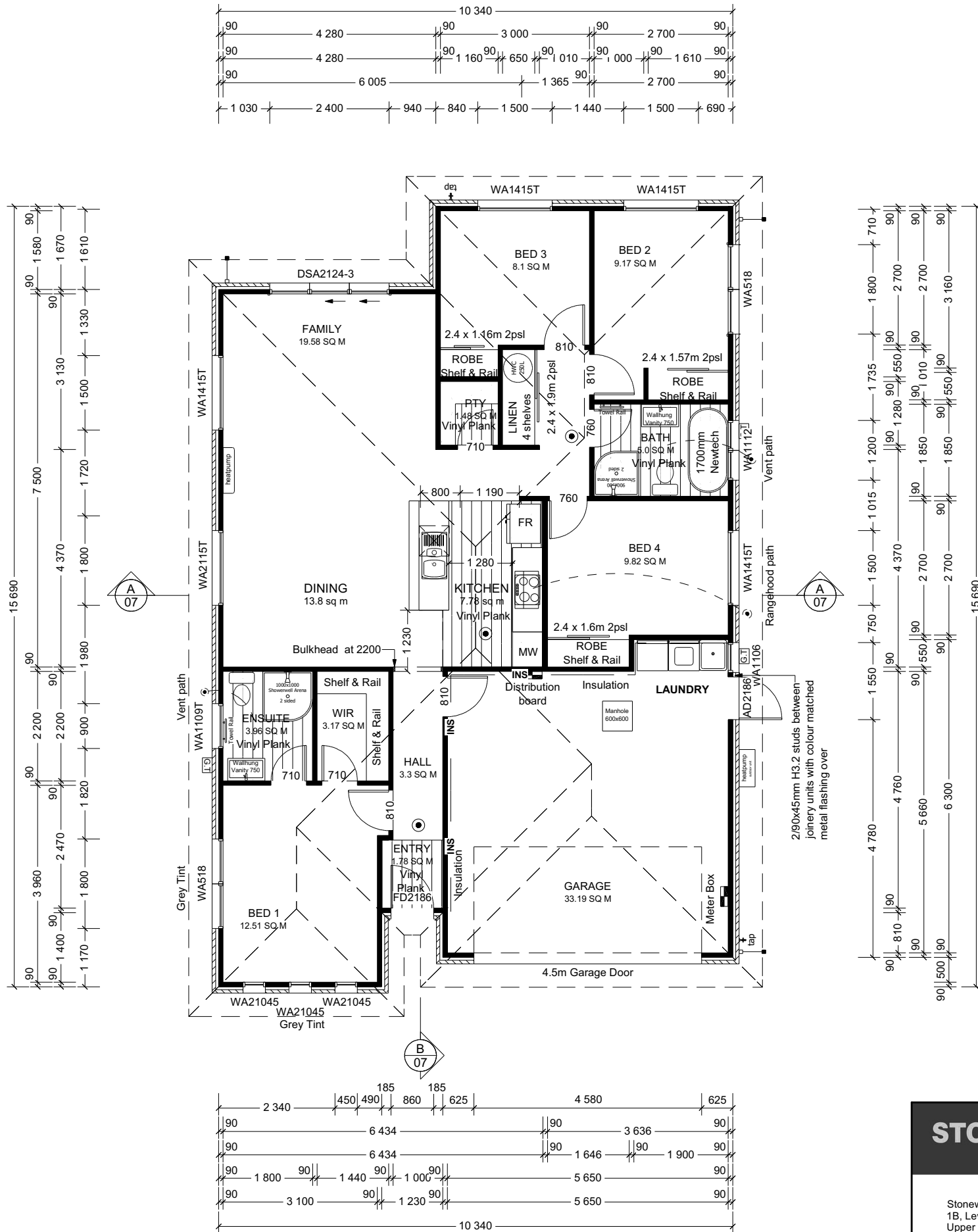

ROOF & WALL CLADDING
Roof - 25° Pressed Tile
Walls - 70 Series Brick Veneer
Feature - 70 Series Brick over 60mm cavity

BUILDING AREA
AREA: 149.66m ² O/F (Perimeter: 53.86m)
AREA: 156.23m ² O/V (Perimeter: 54.90m)
AREA: 183.01 m ² Roof (Perimeter: 56.96m)

GENERAL FLOOR PLAN NOTES
SMOKE ALARMS (hush type) Smoke Alarms to be fitted within 3.0m of sleeping areas and on Escape routes, as indicated on plan. Refer to Construction Schedule (Page 2 & 3) in the Specification for more information.
MISCELLANEOUS: Dimensions shown are to the frame, GIB thickness not shown. Refer to Construction Schedule (Page 2 & 3 of Specification) for additional construction information. Entry through external doors Mechanical ventilation Air Seals to have PEF rod & low expansion foam All windows and doors centered in room unless shown otherwise
GAS Gas Bottles to be installed 1500mm away from any ignition source as per the Gas Cylinder diagram in the Gas section of the main specification. (Anything electrical is an ignition source)
BUILDING WRAP 7mm Ecoply Barrier OR Tekton OR Tyvek, refer to manufacturers specifications attached
WALL FRAMING Stud Height: 2420mm
FLOOR FINISHES Carpet Vinyl Plank
WATER HEATING Electric OR Gas
KITCHEN HOB Gas Hob with Heat resistant splash back OR Electric Hob
DOORS Internal Height: 1980mm Type: TBC Front Door Type: xxx
STAIRS Treads - Risers -

STONWOOD HOMES

Stonewood Homes
1B, Level 1, 303 Blenheim Rd
Upper Riccarton, Christchurch 8041,
New Zealand
Phone: +64 3 354 2344
Fax: +64 3 354 2342
Email: info@stonewood.co.nz
Website: www.stonewood.co.nz

Client: Lot 10 The Link, Rolleston
Proposed Dwelling at:
Lot 10 The Link, Rolleston

This plan is developed for the purchaser and is copyright to Stonewood Homes NZ Franchisor Limited. All dimensions and levels are to be checked and verified on site by contractor prior to commencement of any work

Signed:		Date:	
FLOOR PLAN			
Drawn By Isha	Checked By XXXX XXXXX	LBP # XXXXXX	
Standard Plan	Print Date 22/05/2020	Sales SHC	Scale at A3 1:100
Avon 157 Gable	Version A	Revision 2	Sheet 4
Job Number 200060	Version A	Revision 2	Sheet 4
Version: CONCEPT			OF XX

RISK MATRIX ASSESSMENT		
ELEVATION A		
RISK CRITERIA	RISK	SCORE
Wind Zone	xxx	0
Number of Stories	xxx	0
Roof Wall Junction	xxx	0
Eaves Width	xxx	0
Building Envelope	xxx	0
Decks & Balconies	xxx	0
Total		XX

GENERAL ELEVATION NOTES
Air Barrier to unlined wall and gables, refer to the Construction Schedule in the Specification for type.
This sheet to be read in conjunction with the Risk Matrix in specification.
Driveway to fall from 20mm max below garage rebates (By Others).
Key SS: Security Stay SG: Safety Glass

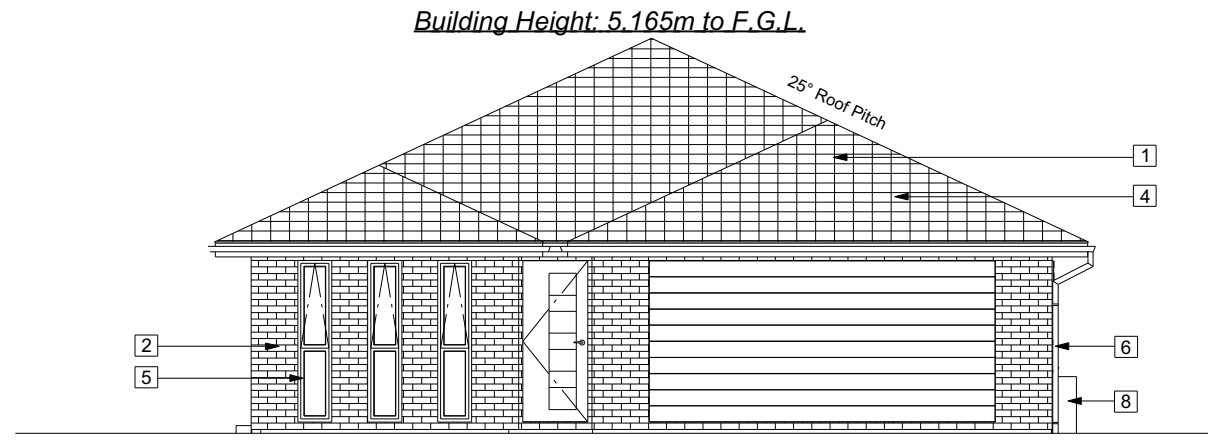

A
4 **ELEVATION A**
1:100

LEGEND
1 - 25° Pressed Tile
2 - 70 Series Brick over 60mm cavity
3 - 70 Series Brick over 60mm cavity
4 - Dimond Fascia and Gutter System
5 - Aluminum Joinery
6 - Colorsteel Downpipe's
7 - Meter Box
8 - Outdoor Heatpump Unit
9 - Terminal Vent

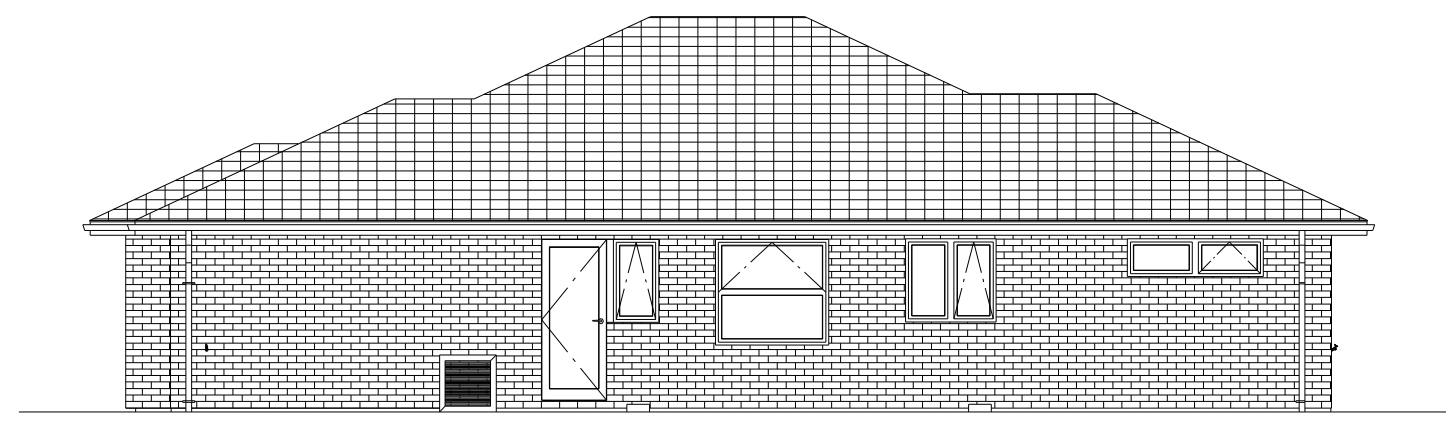

B
4 **ELEVATION B**
1:100

RISK MATRIX ASSESSMENT		
ELEVATION B		
RISK CRITERIA	RISK	SCORE
Wind Zone	xxx	0
Number of Stories	xxx	0
Roof Wall Junction	xxx	0
Eaves Width	xxx	0
Building Envelope	xxx	0
Decks & Balconies	xxx	0
Total		XX

STONEWOOD HOMES

Stonewood Homes
1B, Level 1, 303 Blenheim Rd
Upper Riccarton, Christchurch 8041,
New Zealand
Phone: +64 3 354 2344
Fax: +64 3 354 2342
Email: info@stonewood.co.nz
Website: www.stonewood.co.nz

Client: Lot 10 The Link, Rolleston
Proposed Dwelling at:
Lot 10 The Link, Rolleston

This plan is developed for the purchaser and is copyright to Stonewood Homes NZ Franchisor Limited. All dimensions and levels are to be checked and verified on site by contractor prior to commencement of any work

Signed:	Date:		
ELEVATIONS			
Drawn By Isha	Checked By XXXX XXXXX	LBP # XXXXXX	
Standard Plan	Print Date 22/05/2020	Sales SHC	Scale at A3 1:100
Job Number 200060	Version A	Revision 2	Sheet 5
Version: CONCEPT			OF XX

RISK MATRIX ASSESSMENT		
ELEVATION C		
RISK CRITERIA	RISK	SCORE
Wind Zone	xxx	0
Number of Stories	xxx	0
Roof Wall Junction	xxx	0
Eaves Width	xxx	0
Building Envelope	xxx	0
Decks & Balconies	xxx	0
Total		XX

GENERAL ELEVATION NOTES
Air Barrier to unlined wall and gables, refer to the Construction Schedule in the Specification for type.
This sheet to be read in conjunction with the Risk Matrix in specification.
Driveway to fall from 20mm max below garage rebates (By Others).
Key SS: Security Stay SG: Safety Glass

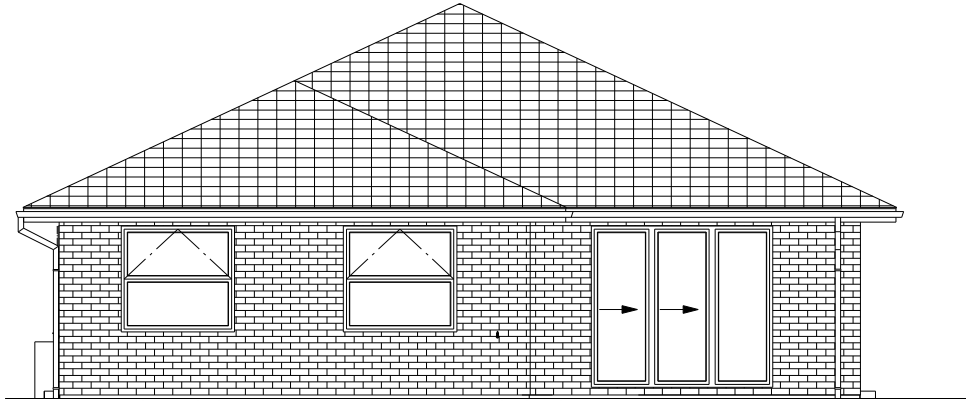

C
4
ELEVATION C
1:100

LEGEND
1 - 25° Pressed Tile
2 - 70 Series Brick over 60mm cavity
3 - 70 Series Brick over 60mm cavity
4 - Dimond Fascia and Gutter System
5 - Aluminum Joinery
6 - Colorsteel Downpipe's
7 - Meter Box
8 - Outdoor Heatpump Unit
9 - Terminal Vent

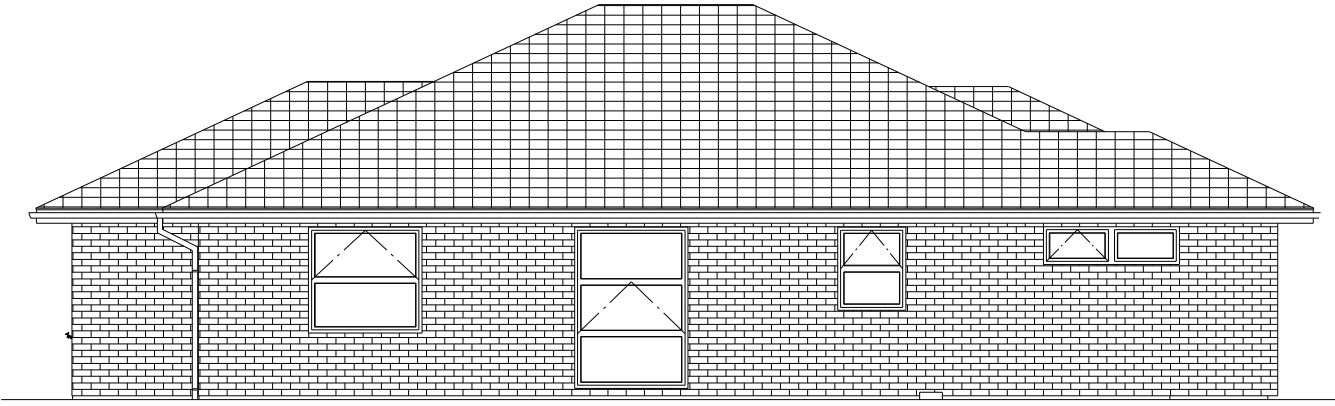

D
4
ELEVATION D
1:100

RISK MATRIX ASSESSMENT		
ELEVATION D		
RISK CRITERIA	RISK	SCORE
Wind Zone	xxx	0
Number of Stories	xxx	0
Roof Wall Junction	xxx	0
Eaves Width	xxx	0
Building Envelope	xxx	0
Decks & Balconies	xxx	0
Total		XX

STONEWOOD
HOMES

Stonewood Homes
1B, Level 1, 303 Blenheim Rd
Upper Riccarton, Christchurch 8041,
New Zealand
Phone: +64 3 354 2344
Fax: +64 3 354 2342
Email: info@stonewood.co.nz
Website: www.stonewood.co.nz

Client: Lot 10 The Link, Rolleston
Proposed Dwelling at:
Lot 10 The Link, Rolleston

This plan is developed for the purchaser and is copyright to Stonewood Homes NZ Franchisor Limited. All dimensions and levels are to be checked and verified on site by contractor prior to commencement of any work

Signed:	Date:		
ELEVATIONS			
Drawn By Isha	Checked By XXXX XXXXX	LBP # XXXXXX	
Standard Plan	Print Date 22/05/2020	Sales SHC	Scale at A3 1:100
Job Number 200060	Version A	Revision 2	Sheet 6
Version: CONCEPT			OF XX

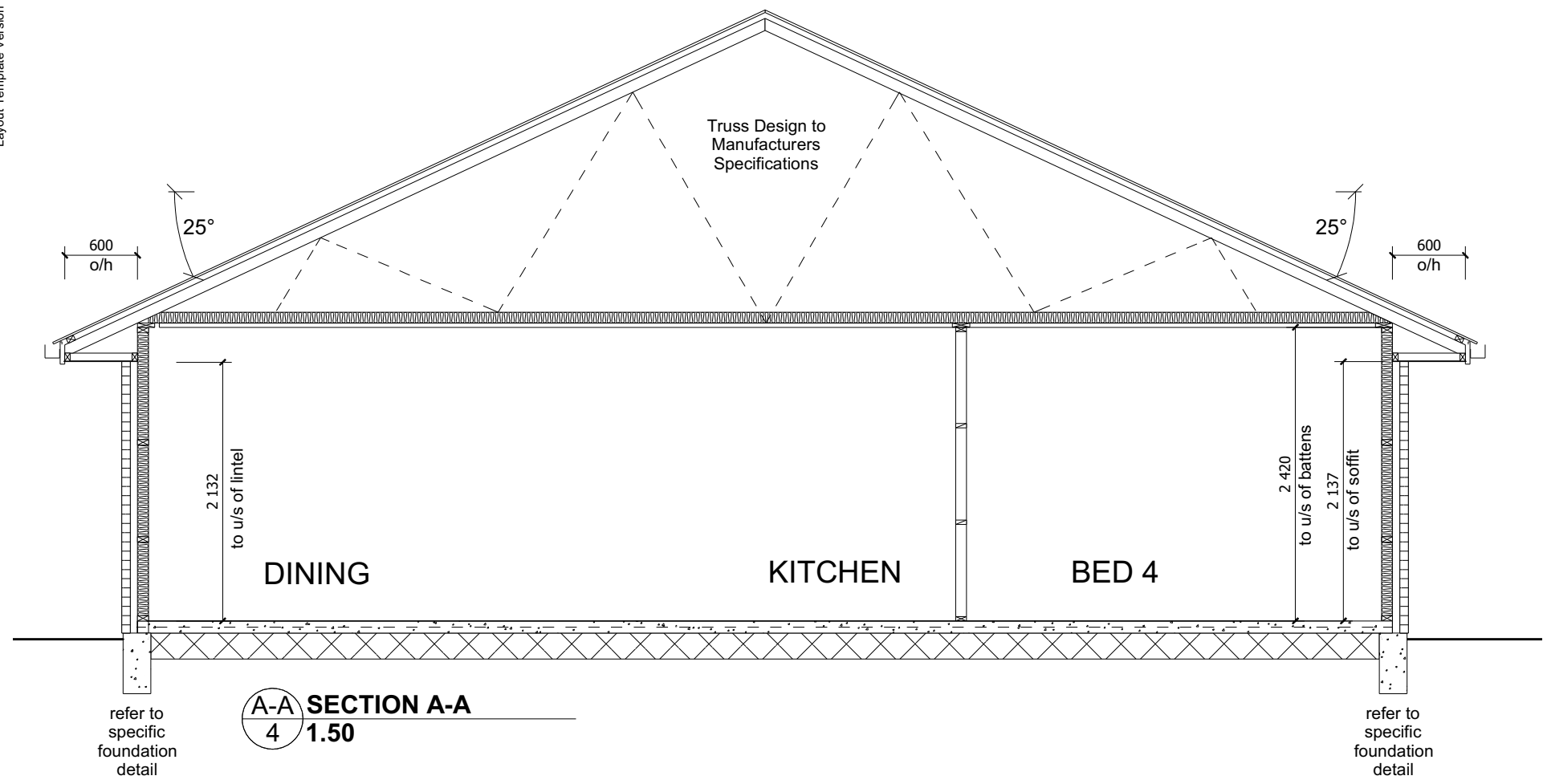

A-A SECTION A-A
4 1.50

refer to specific foundation detail

refer to specific foundation detail

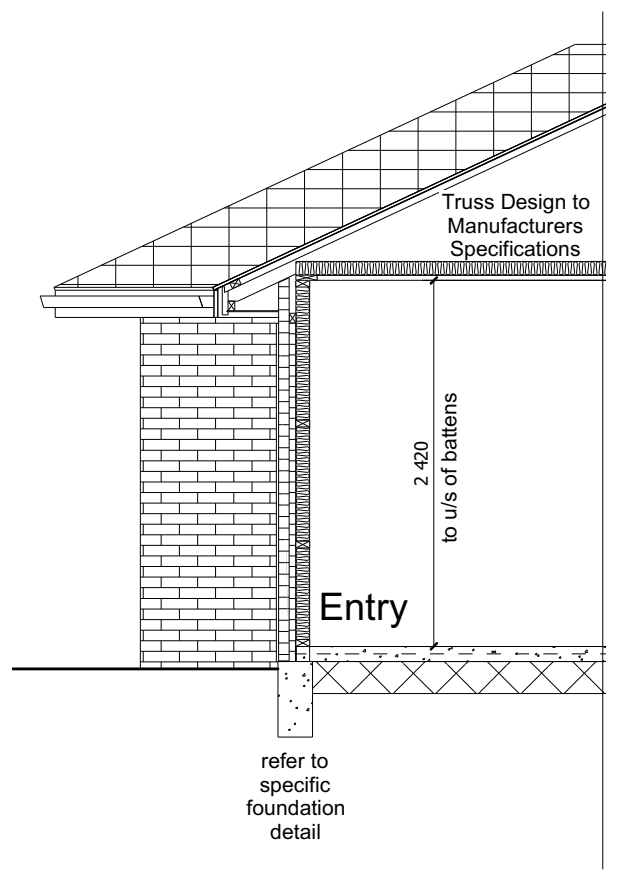

B-B SECTION B-B
4 1.50

refer to specific foundation detail

PROTECTION OF FIXINGS
Fixings shall comply with NZS 3604:2011 Section 4 Durability Tables 4.1-4.3
CONCRETE STRENGTH
All concrete to comply with NZS3604:2011 Section 4 Durability Clause 4.5.2
TIMBER GRADE
Timber members specified on these drawings are to be a minimum of SG8 strength graded as per NZS3604:2011

GENERAL ELEVATION NOTES	
Refer to the Construction Schedule (Page 2 & 3) in the Specification for further information.	

INSULATION	
Wall -	Pink Batts R.... Wall Batts
Ceiling -	Pink Batts R.... Ceiling Batts

LEGEND	
1 -	
2 -	
3 -	
4 -	
5 -	
6 -	
7 -	
8 -	
9 -	
10 -	
11 -	
12 -	
13 -	
14 -	
15 -	

STONEWOOD HOMES

Stonewood Homes
1B, Level 1, 303 Blenheim Rd
Upper Riccarton, Christchurch 8041,
New Zealand
Phone: +64 3 354 2344
Fax: +64 3 354 2342
Email: info@stonewood.co.nz
Website: www.stonewood.co.nz

Client: Lot 10 The Link, Rolleston
Proposed Dwelling at:
Lot 10 The Link, Rolleston

This plan is developed for the purchaser and is copyright to Stonewood Homes NZ Franchisor Limited. All dimensions and levels are to be checked and verified on site by contractor prior to commencement of any work

Signed:	Date:		
CROSS SECTION			
Drawn By Isha	Checked By XXXX XXXXX	LBP # XXXXXX	
Standard Plan Avon 157 Gable	Print Date 22/05/2020	Sales SHC	Scale at A3 1:50
Job Number 200060	Version A	Revision 2	Sheet 7
Version: CONCEPT	OF XX		

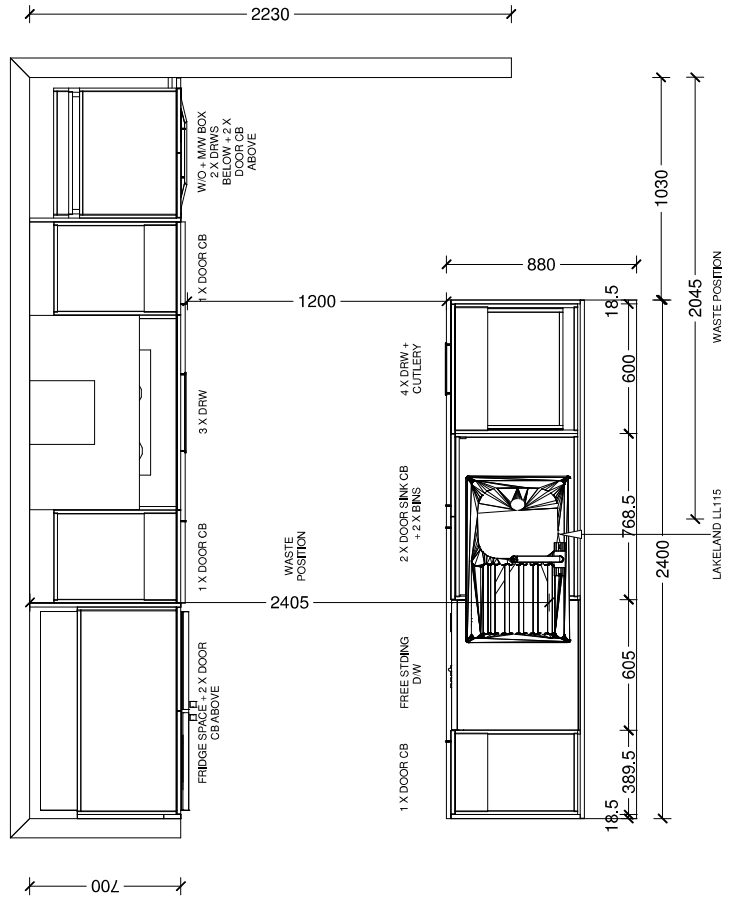
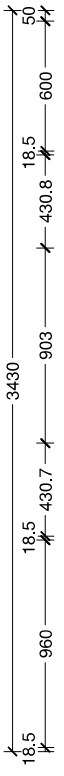
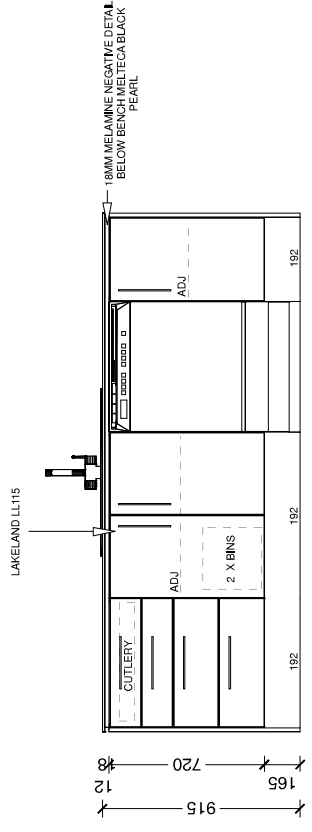
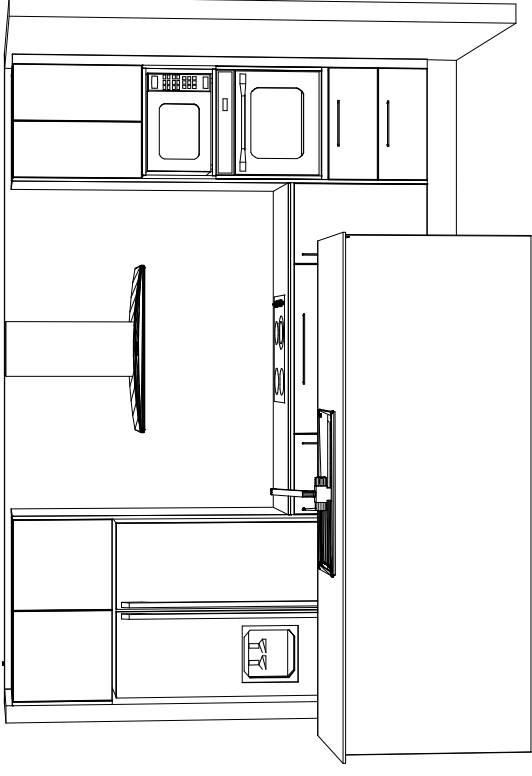
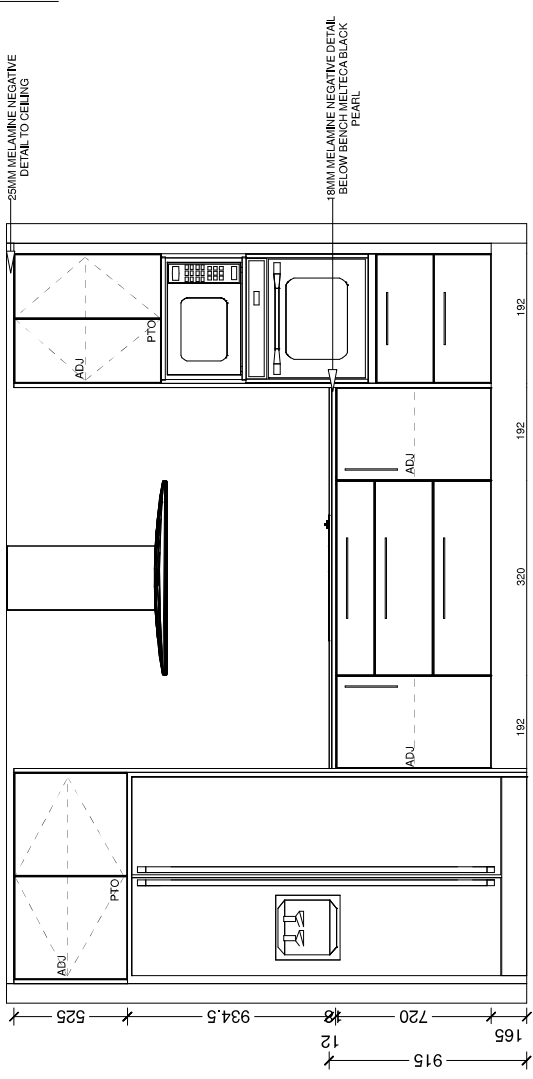

Designer: Teresa	Date: 22 Aug 19	Client: Stonewood Homes	BC Ref: Job	Site Address:
Dwg: XXXXXXXXXX	Rev: XX	Customer: The Avon Kitchen	Job#: Default	

This is an original design and must not be released or copied unless applicable fee has been paid or job order placed. All dimensions and size designations given are subject to verification on job site and adjustment to fit job conditions.

TRENDS
KITCHENS

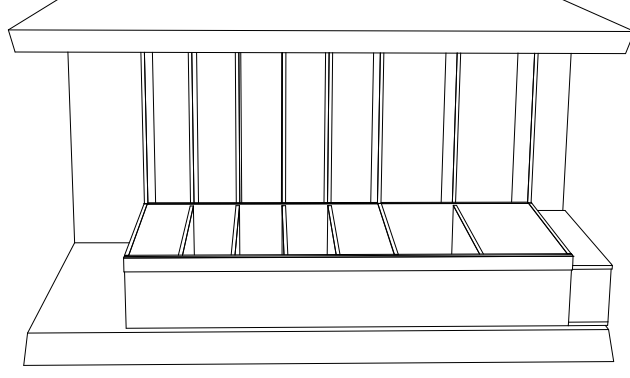
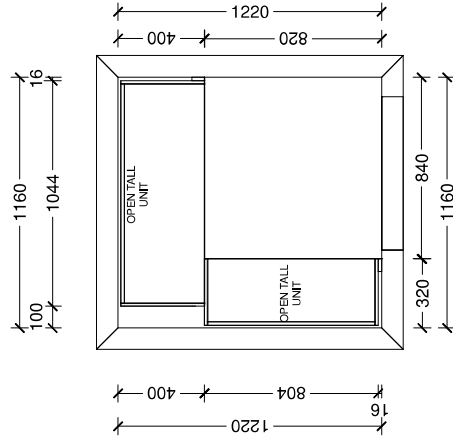
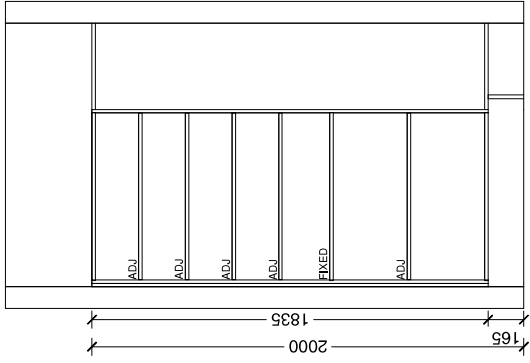

Designer: Teresa

Date: 22 Aug 19

Client: Stonewood Homes

Site Address:

Job#: Default

Dwg: xxxxxxxxxx

Rev: XX

Customer: The Avon Walk-In Pantry



This is an original design and must not be released or copied unless applicable fee has been paid or job order placed. All dimensions and size designations given are subject to verification on job site and adjustment to fit job conditions.

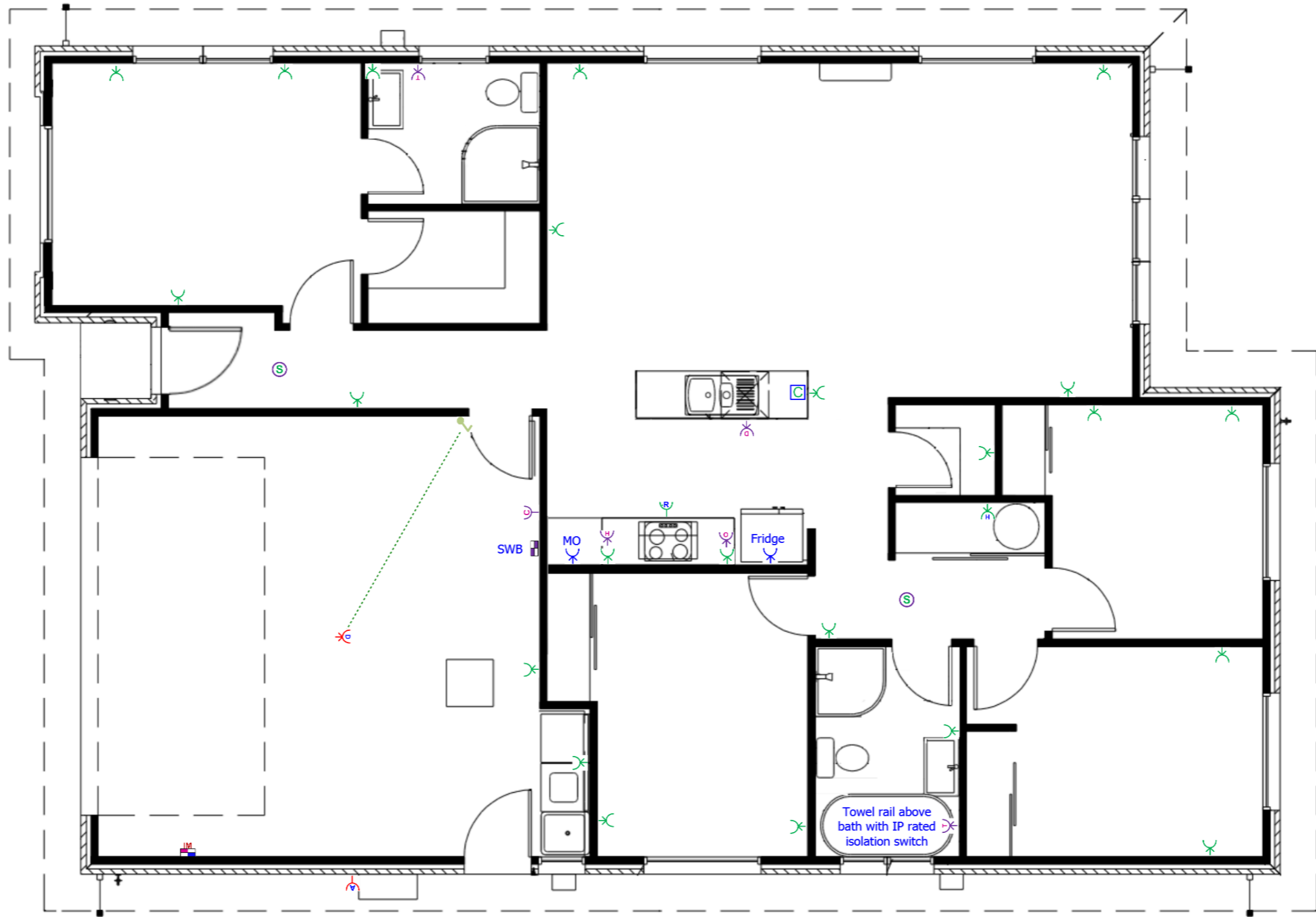

Signature: _____ Date: _____



Electrical Power

Stonewood Homes WPL - The Avon,
 Lot 28 Ridgway Ave
 Rolleston, Rolleston

Christchurch
 PO Box 9302
 Tower Junction
 Christchurch

Phone: 03 338 4238
 Fax: 03 338 4239
 Web: smartsystems.net.nz
 Email: info@smartsystems.net.nz

Designed by: Michael Gilbert

Drawing Not To Scale

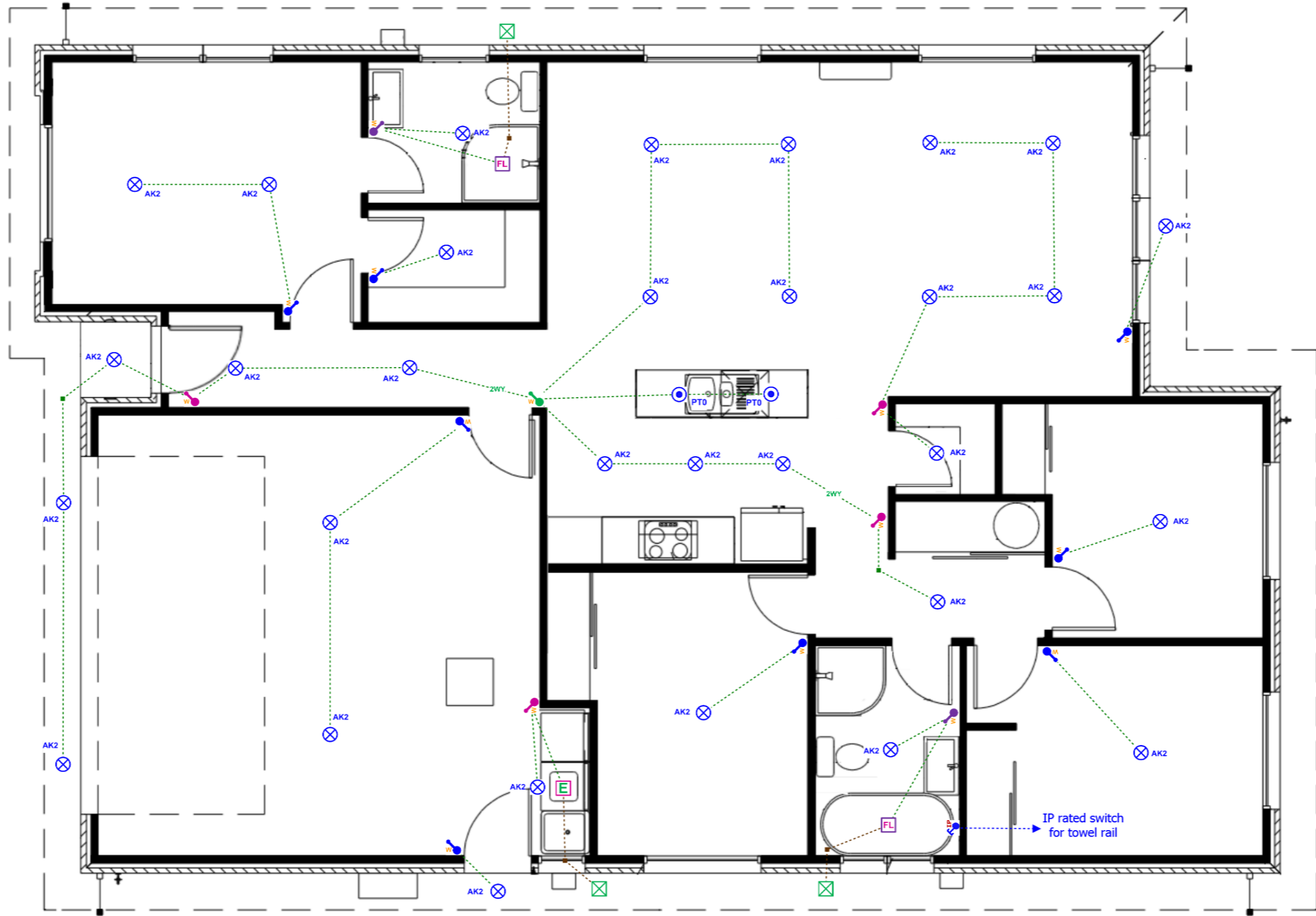

Signature: _____ Date: _____

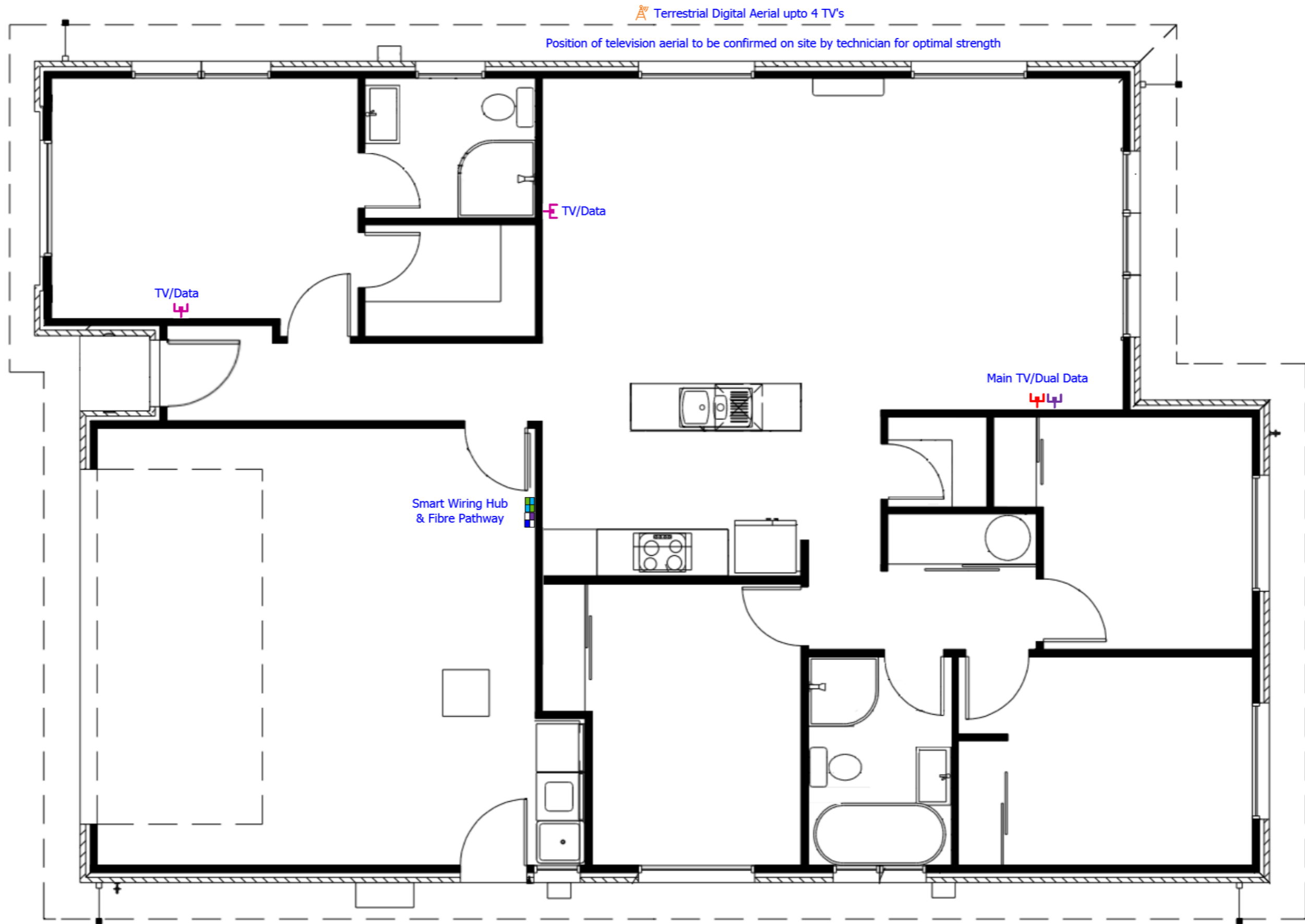

Terrestrial Digital Aerial upto 4 TV's

Position of television aerial to be confirmed on site by technician for optimal strength

TV/Data

TV/Data

Smart Wiring Hub
& Fibre Pathway

Main TV/Dual Data



Signature: _____ Date: _____



Structured Cabling

Stonewood Homes WPL - The Avon,
Lot 28 Ridgway Ave
Rolleston, Rolleston

Christchurch
PO Box 9302
Tower Junction
Christchurch

Phone: 03 338 4238
Fax: 03 338 4239
Web: smartsystems.net.nz
Email: info@smartsystems.net.nz

Designed by: Michael Gilbert

Drawing Not To Scale

Key & Specification

Date 18/03/2020















To

Stonewood Homes WPL - The Avon
PO Box 16499
Hornby
Christchurch 8441









Site Address





Lot 28 Ridgway Ave
Farringdon Courts

Job No 2038 **Customer ID** 105963 **Building Co Order** **Sales Person** Michael Gilbert







Class	Job Description	Quantity
Electrical Power:		
 EP011001	Electrical Base for 30 way switchboard	1
 EP025121	Internal flush mounted meter box Please Note: meter box mounted directly above the ducts for the mains cable on the internal side of the wall. No allowance to move meter box for bracing.	1
 EP100082	Rangehood plug socket (no switch) white	1
 EP100110	Smart wiring power sockets for hub white	1
 EP141001	Voltex classis single power socket 10A white	2
 EP141021	Voltex classic double power socket horizontal white 10A	23
 EP141071	Voltex classic garage door single power socket and press switch 10A white	1
 EP141111	Voltex classic single power socket for dishwasher 10A white	1
 EP141151	Voltex classic built in oven connection & isolation switch max 20m from switchboard & up to 20A max	1
 EP141161	Voltex classic electric hob connection & isolation switch up to 20m from switchboard & 32A max	1
 EP141221	Voltex classic hot water cylinder connection standard tariff white	1
 EP210001	Air conditioning outside unit power and isolation switch 16A max single phase	1
 EP220001	Smoke detector mains powered with 9V battery backup	2
 EP222501	Capping for sockets and/or switches in joinery	1
 EP901521	Voltex classic heated towel rail power connection & installation Please note: no towel rail included in this costing	2

Lighting Circuits:

 EL100101	PDL 600 series white light switch 1 gang IP rated	1
 EL110034	Recessed light circuit	31
 EL110035	Pendant light circuit	2
 EL110151	Extractor fan circuit and installation only Please Note: extractor fan not included in costing	1
 EL110201	2 way light circuit	2
 EL130501	Voltex classic 1-gang light switch white	8
 EL130505	Voltex classic 2-gang light switch white	4
 EL130510	Voltex classic 3-gang light switch white	2

 EL130515	Voltex classic 4-gang light switch white	1
 EL180008	Extractor fan/light circuit & install only Please note: fan/light not included	2
 EL202330	Prolux LED downlight DL54 10W 3K 850 lumen white	31
 EL297941	Newtown black 1/L 160mm pendant light with 40W carbon filament lamp	2

Structured Cabling:

 SC001111	Smart wiring base 12 data sockets 20" hub	1
 SC050005	Fibre optic ducted pathway to external demarcation point	1
 SC120151	Voltex classic Cat6 data socket 1Gb/s white	1
 SC240701	Voltex classic TV/data socket cat6 1Gb/s white	2
 SC240801	Voltex classic main TV & data socket cat6 1Gb/s white	1
 SC402001	Digital terrestrial aerial suitable for Freeview HD up to 4 TV outlets Please note: Freeview HD reception requires line of sight to the transmitter and signal levels and quality can not be confirmed until a site visit is completed. Any further hardware or upgrade of aerial materials not included in quote.	1